



Data Sheet

Coaxial Relay CX-600NC

MECHANICAL CHARACTERISTICS :

Contact Arrangement	SPDT
Operational Temperature	- 25 °C to + 50 °C
Max Temperature Rise	20 °C
Weight	Approx. 230 g
Mounting	Four screws
Cable Connections	1x N type female connector, 2x direct connection of cables

ELECTRICAL CHARACTERISTICS :

Impedance	50 Ohms
Nominal Voltage	12 V DC
Voltage Range	10 V DC - 14 V DC
Current	160 mA @12 V DC 20 °C
Coil Resistance	75 ±10% Ohms @ 20 °C

RF-PROPERTIES :

Frequency	VSWR	Isolation	Ins. Loss	RF Power input
MHz	max	-dB(min) ±3 dB	-dB(max)	W (PEP)
50	1.03	60	0.07	1000
150	1.10	48	0.10	1000
500	1.15	37	0.15	800
1000	1.20	28	0.20	500
1500	1.20	26	0.20	350
2000	1.25	22	0.23	100

ACTUATION DATA :

Pull In	10 V DC - 14 V DC (12 V DC Nominal)
Drop Out	3 V DC min.

SWITCHING TIME :

Pull In	20 ms max.
Drop Out	15 ms max.
Life Expectancy	1.000.000 Operations min.

Coaxial Relay CX-600NC

DIMENSIONS :

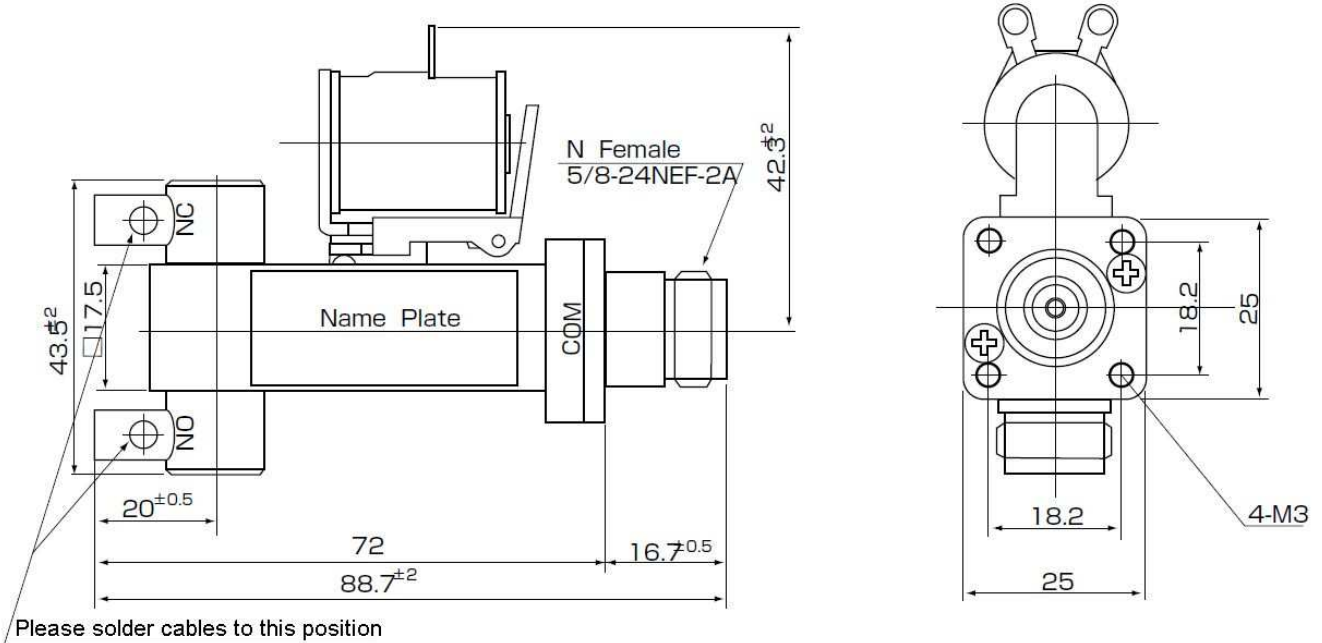

Typical Operating Curves :

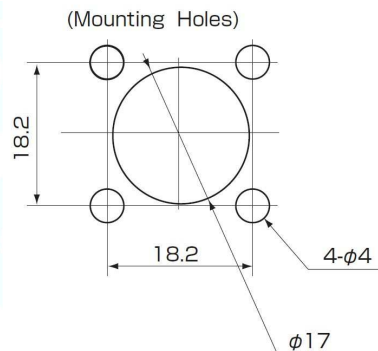
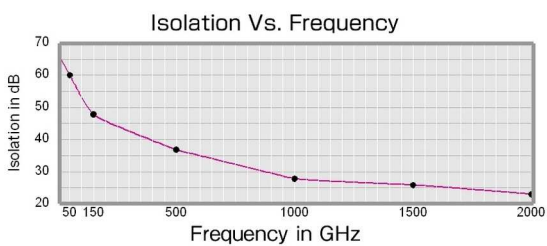
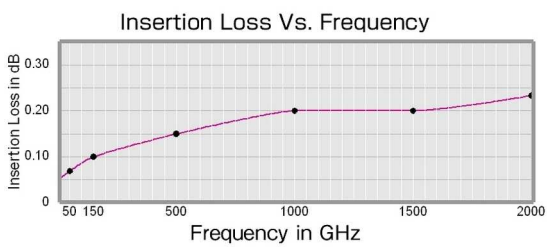
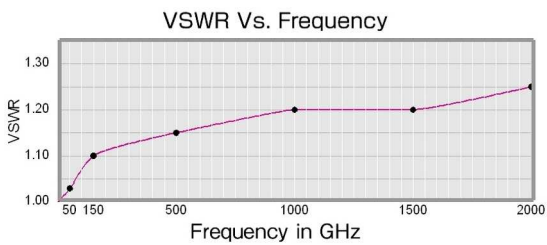

Schematic:

